

Flow Monitor & Flow Indicator

DKG-1



OVERVIEW

Operation

- Float measuring principle

Application

- Mechanical engineering
- Central lubrication
- Circulation lubrication
- Transformers

Features

- Universal orientation
- High reliability
- High switch accuracy
- Viscosity compensated
- Infinitely variable switch point adjustment by operator
- EX-version according to ATEX directive available
- UL Recognized version available
- Scales are burned onto the sight glass
- Threaded connection, special thread on request

Installation information

- The operating instructions for DKG-1 Module BASICS / ...ATEX must be observed!
- **Download: www.meister-flow.com**

OPERATING DATA

Operating pressure, max.	10 bar
Pressure drop	0,02 – 0,4 bar
Viscosity range	30 cSt to 600 cSt
Temperature, max.	120 °C (optional 160 °C)
Measuring accuracy	±10 % of full scale

Changed operating data apply to the devices in explosion-proof design according to ATEX directive. Refer to the Operating Instructions for DKG-1 Module ATEX.

For UL Recognized devices, changed operating data apply. Refer to the Operating Instructions for DKG-1 Module BASICS.

Download: www.meister-flow.com

MEASURING RANGES

Type	Switch range for Oil, density 0,9 kg/dm ³ ⁽¹⁾		
	l/min	gph	gpm
DKG-1/2	0,5 – 1,5	8 – 24	
DKG-1/4	1 – 4	16 – 63	
DKG-1/8	2 – 8	32 – 127	
DKG-1/10	3 – 10	48 – 159	
DKG-1/15	5 – 15	80 – 240	
DKG-1/24	8 – 24	125 – 380	
DKG-1/30	10 – 30	160 – 475	
DKG-1/45	15 – 45	240 – 710	
DKG-1/60	20 – 60	320 – 950	
DKG-1/90	30 – 90		8 – 24

⁽¹⁾ The specified measuring- /switch ranges are valid for oils having a density of 0.9 kg/dm³ and a kinematic viscosity of 30 to 600 cSt, vertical installation of the device and flow direction from bottom to top.

Other installation positions or deviation from the operating densities and operating viscosities will increase the measurement error specified in the data sheet. Excessive operating viscosities will influence or may prevent function of the device.

Upon request, special scales for deviating media, different operating conditions and installation positions (only for devices which can be installed in any position) are available.

The specified switch values are switch-off points, i.e. switch values by decreasing flow.

Other measuring- /switch ranges are available upon request.

MATERIALS

Brass version, wetted parts

Spring:	1.4571
Sight glass:	DURAN® 50
Gaskets:	FKM (optional NBR, EPDM) ⁽³⁾
Magnets:	Hard ferrite
all other wetted parts:	Brass, nickel-plated

Brass version, non-wetted parts

Device housing:	Aluminium, anodized
-----------------	---------------------

Stainless steel version, wetted parts

Spring:	1.4571
Sight glass:	DURAN® 50
Gaskets:	FKM (optional NBR, EPDM) ⁽³⁾
Magnets:	Hard ferrite
all other wetted parts:	1.4571

Stainless steel version, non-wetted parts

Device housing:	Aluminium, anodized
-----------------	---------------------

⁽³⁾ Other gasket materials on request

TECHNICAL DRAWING

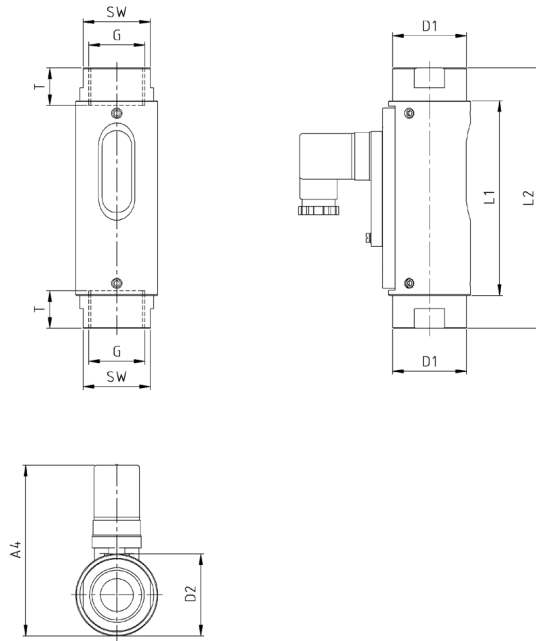

SUMMARY OF TYPES

Type	Overall dimensions [mm]												Weight approx. [g]
	G	DN	SW	L1	L2	T	D1	D2	A1	A2	A3	A4	
DKG-1/2 DKG-1/4	1/4"	8	41	118,5	144,5	10	45	50	-	-	-	~104	850
	1/2"	15	41	118,5	144,5	14	45	50	-	-	-	~104	850
	3/4"	20	41	118,5	138,5	15	45	50	-	-	-	~104	850
	1"	25	41	118,5	158,5	17	45	50	-	-	-	~104	900
DKG-1/8													
DKG-1/10	1/2"	15	41	118,5	144,5	14	45	50	-	-	-	~104	850
	3/4"	20	41	118,5	138,5	15	45	50	-	-	-	~104	850
DKG-1/15	1"	25	41	118,5	158,5	17	45	50	-	-	-	~104	900
DKG-1/24													
DKG-1/30													
DKG-1/45	3/4"	20	41	118,5	138,5	15	45	50	-	-	-	~104	850
DKG-1/60	1"	25	41	118,5	158,5	17	45	50	-	-	-	~104	900
DKG-1/90													

ELECTRICAL DATA

Change over (COC)	250V · 1,5A · 50VA ⁽⁴⁾
Normally open (NOC)	250V · 3A · 100VA
Change over M12x1 (-20 °C – 85 °C)	250V · 1,5A · 50VA ⁽⁴⁾
Normally open M12x1 (-20 °C – 85 °C)	250V · 3A · 100VA
Change over PLC	250V · 1A · 60VA

EX-version in compliance with ATEX directive

ATEX II 2 G Ex mb IIC T6 Gb & ATEX II 2 D Ex tb IIIC T80 °C Db	
ATEX II 2 G Ex mb IIC T5 Gb & ATEX II 2 D Ex tb IIIC T100 °C Db	
Change over	250V · 1A · 30VA ⁽⁴⁾
Normally open	250V · 2A · 60VA

UL Recognized switch contacts

Change over	240V · 1,5A · 50VA ⁽⁴⁾
Normally open	250V · 3A · 100VA

⁽⁴⁾ Minimum load 3VA

ELECTRICAL CONNECTION

- Connector in compliance with EN 175301-803, Form A (DIN 43650, Form A)
- Connector M12x1
- Cable (1 m)

EX-version in compliance with ATEX directive

- Cable (2 m)

UL Recognized switch contacts

- Connector in compliance with EN 175301-803, Form A
- Cable (1 m)

Ingress Protection

IP65: Connector in compliance with EN 175301-803, Form A
IP67: Cable or connector M12x1

Output signal

The contact opens / changes when the flow decreases below the set point.

Power supply

Not required (potential-free reed contacts)

Connector types

Other connector types or cable lengths on request

CONNECTION DIAGRAM

